

■ ■ ■ ■ IN - STACK VERSION ■ ■ ■ ■

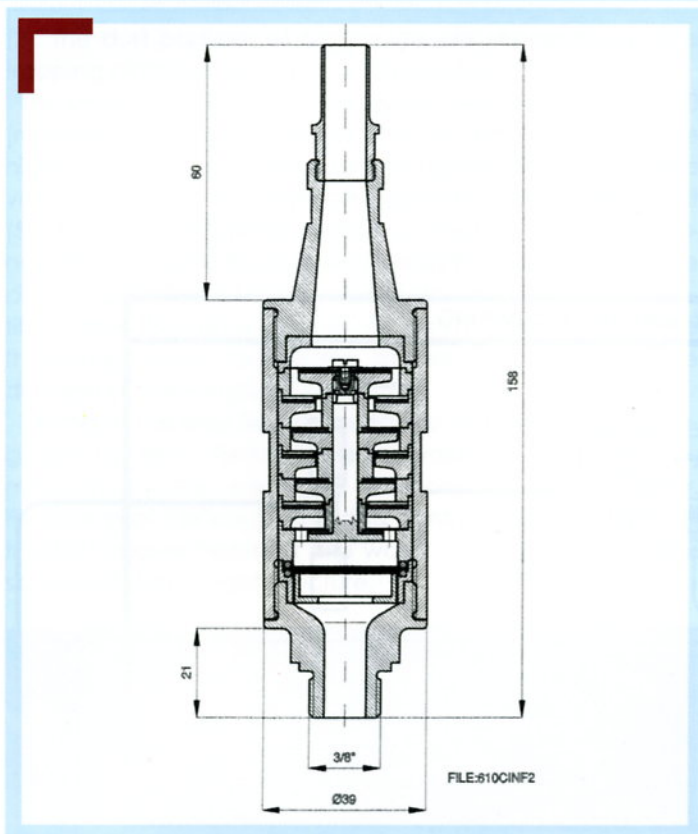

SPECIAL FEATURES

- Seven impactor stages.
- Rapidly changeable impactor stages suitable for performing sequential, continuously periodical measurements.
- 30% smaller external dimensions, 40% less mass, performing the same flow rate.
- The chambers of the impactor stages can be well separated by scaling.
- Cleaning and the periodic size-control of the annular vent nozzles are extremely simple.
- Dust storage capacity is variable by the changing of the collector plates.
- The static and dynamic pressure exhaust probes and the temperature sensor are assembled together in the probe shank.
- Automatic, isokinetic sampling, measurement control and evaluation by the KS-400-CV.15/8 type device along with a Windows based software.

1. Purpose

The **KS-404** type portable, partial gas flow emission type sampling circuit implemented with the **OH-610-C** type 7 staged cascaded impactor – in automatic operation – is capable of the isokinetic, continuously periodical, total or fractionated sampling of solid particles in flowing air or gas.

2. Technical description

The seven stage cascade impactor **OH-610-C** type device offers completely new solutions. Its evaluation system follows the latest fluid mechanical configurations. For the sake of increasing the impact effect and decreasing dimensions, particles are accelerated in an annular nozzle to the proper impact velocity.

The separation characteristics of the **OH-610-C** impactor are represented in **Figure 1**. The impactor in a disassembled state is shown in **Figure 2**.

SERIES OH-610-C IN STACK CASCAD IMPACTOR 50 [%] EFFECTIVE CUT DIAMETER							
Rep = 1,0 [kg/dm ³] t = 20 [°C]	Stage 1.	Stage 2.	Stage 3.	Stage 4.	Stage 5.	Stage 6.	Stage 7.
q = 1,0 [m ³ /h]	7,0	3,4	1,8	0,81	0,45	0,19	0,11
q = 1,2 [m ³ /h]	6,4	3,1	1,6	0,74	0,40	0,17	0,09
q = 1,5 [m ³ /h]	5,7	2,7	1,4	0,65	0,35	0,14	0,08
q = 1,8 [m ³ /h]	5,2	2,5	1,3	0,59	0,32	0,13	0,07
q = 2,0 [m ³ /h]	4,9	2,4	1,2	0,6	0,3	0,1	0,06

Figure 1.

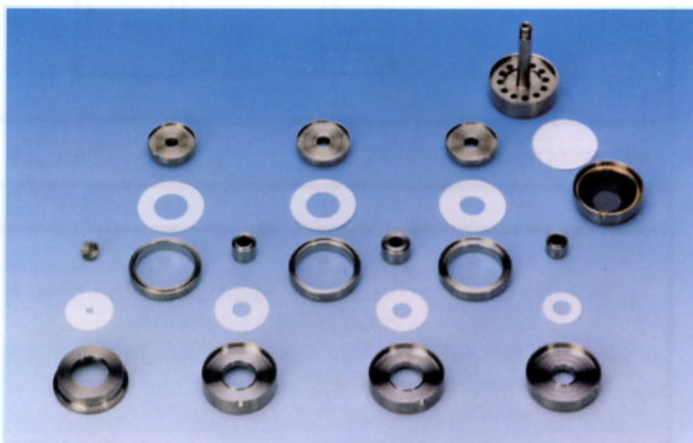

Figure 2.

2. Technical data

- Nominal flow rate depending on t1 1,5-2,3 [m³/h]
- Measuring range 0,9 to 2,6 [m³/h]
- Aerodynamic resistance with clean filter 115 [mbar]
q = 1,5 [m³/h]
ρ = 1,2 [kg/m³]
- Number of impactor stages 7
- Particle separation values – cut points AR-COM OH-610-C v1,0 software
- Max. temp. with Teflon gasket 180 [°C]
- Nozzles Ø 4,5; 5,6; 7,6; 10,7; 14; 17 [mm]
- Optional nozzles Ø 5,0; 6, 2; 6,9; 8,5; 9,5 [mm]
- Back-up filter Ø 30 [mm]