

MODEL OH-610-B

SIX-STAGE CASCAD IMPACTOR WITH BACKUP FILTER FOR THE FRACTIONATED SAMPLING OF SOLID PARTICLES AND AEROSOLS

■■■■ IN - STACK VERSION ■■■■



SPECIAL FEATURES

- Six impactor stages.
- Rapidly changeable impactor stages suitable for performing sequential, continuously periodical measurements.
- 30% smaller external dimensions, 40% less mass, performing the same flow rate.
- The chambers of the impactor stages can be well separated by scaling.
- Cleaning and the periodic size-control of the annular vent nozzles are extremely simple.
- Dust storage capacity is variable by the changing of the collector plates.
- The static and dynamic pressure exhaust probes and the temperature sensor are assembled together in the probe shank.
- Automatic, isokinetic sampling, measurement control and evaluation by the KS-400-CV.15/8 type device along with a Windows based software.



creasing the impact effect and decreasing dimensions, particles are accelerated in an annular nozzle to the proper impact velocity. The **OH-610-B** type cascaded impactor consists of a lead-in diffuser, six impactor stages and a backup filter. To avoid reproduction errors occurring owing to the different adhesive capacity of particles, stages have a chamber configuration and are properly separated by scaling. **Figure 1.** shows the cross-section of the **OH-610-B** type impactor assembled. The separation characteristics of the **OH-610-B** impactor, are represented in **Figure 2.**

1. Purpose

The **KS-404** type portable, partial gas flow emission type sampling circuit implemented with the **OH-610-B** type 6 staged cascaded impactor – in automatic operation – is capable of the isokinetic, continuously periodical, total or fractionated sampling of solid particles in flowing air or gas.

2. Technical description

The six stage cascade impactor **OH-610-B** type device offers completely new solutions. Its evaluation system follows the latest fluid mechanical configurations. For the sake of in-

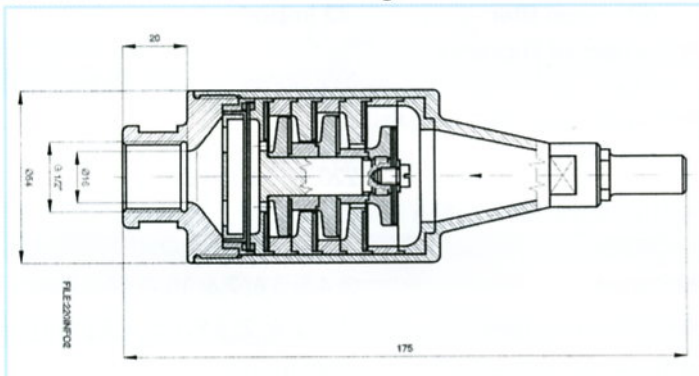

Figure 1.

■■■■ 6 ■■■■

SERIES OH-610-B CASCADE IMPACTOR
50 [%] EFFECTIVE CUT DIAMETER

$R_{op} = 1,0 \text{ [kg/dm}^2\text{]}$ $t = 20 \text{ [}^\circ\text{C]}$	Stage 1.	Stage 2.	Stage 3.	Stage 4.	Stage 5.	Stage 6.
$q = 1,0 \text{ [m}^3\text{/h]}$	18,0	10,4	6,0	4,1	2,1	1,3
$q = 1,2 \text{ [m}^3\text{/h]}$	16,4	9,5	5,5	3,7	1,9	1,2
$q = 1,5 \text{ [m}^3\text{/h]}$	14,7	8,5	4,9	3,3	1,7	1,1
$q = 1,8 \text{ [m}^3\text{/h]}$	13,4	7,7	4,5	3,0	1,5	0,95
$q = 2,0 \text{ [m}^3\text{/h]}$	12,7	7,3	4,2	2,8	1,4	0,90

Figure 2.

3. Technical data

- Nominal flow rate depending on t_1 1,5-2,3 [m³/h]
- Measuring range 0,9 to 2,6 [m³/h]
- Aerodynamic resistance with clean filter 42 [mbar],
 $q=1,5 \text{ [m}^3\text{/h]}$
 $120=1,2 \text{ [kg/m}^3\text{]}$
- Number of impactor stages 6
- Particle separation values – cut points AR-COM OH-610-B v1.0 software
- Max. temp. with Teflon gasket 180 [°C]
- Nozzles $\varnothing 4,5; 5,6; 7,6; 10,7;$
 $14; 17 \text{ [mm]}$
- Optional nozzles $\varnothing 5,0; 6, 2; 6,9; 8,5;$
 $9,5 \text{ [mm]}$
- Back-up filter $\varnothing 43 \text{ [mm]}$

■■■■ MODEL KS-610-B ■■■■